

## Approval Sheet



(V1.0)

**Model Name:**

**WNC P/N:**

**Customer P/N:**

**Description:**

**PCB Ver.:** CM90200B

**Prepared By:** Bryant Lai

**Checked By:** Simon Chien

**Approved By:** Ray Lee

This document contains proprietary information which is the property of **Wistron NeWeb Corporation** and is strictly confidential and shall not be disclosed to others in whole or in part, reproduced, copied, or used as basic for design, manufacturing or sale of apparatus without the written permission of **Wistron NeWeb Corporation Revision History**.



<i>Edition #</i>	<i>Reason for revision</i>	<i>Issue date</i>
V1.0	● Initial Document	3/13,2006



## **1. Introduction**

The CM9-GP (RoHS) is a mini PCI solution for IEEE 802.11a/b/g wireless LAN. With 802.11b mode, it provides data rates of 1, 2, 5.5, and 11Mbps, supporting IEEE 802.11b network specification for Direct Sequence Spread Spectrum (DSSS) signaling. With 802.11a mode, it implements a half-duplex, orthogonal frequency division multiplexing (OFDM) technology supporting all IEEE 802.11a data rates (6 to 54Mbps). 802.11g mode is also provided to support 1 to 54Mbps with DSSS or OFDM technology. This card is a good solution for users who need mini PCI 802.11a/b/g WLAN functionality.

### **1.1. Scope**

This document describes the hardware architecture and specification for the CM9-GP (RoHS).

### **1.2. Product Features**

- ✓ High speed for wireless LAN connection: IEEE802.11b 11Mbps data rate by incorporating Direct Sequence Spread Spectrum (DSSS); IEEE802.11a 54Mbps data rate with Orthogonal Frequency Division Multiplexing (OFDM) and up to 108Mbps with Turbo mode; IEEE802.11g 54Mbps data rate with OFDM (108Mbps in Turbo mode) and 11Mbps with DSSS. Provide seamless roaming within the IEEE 802.11a/b WLAN infrastructure
- ✓ RoHS compliant
- ✓ IEEE 802.11a/b/g compatible: allowing inter-operation among multiple vendors
- ✓ Support Wake on LAN (subject to software)
- ✓ 64-bit, 128-bit, or 152-bit WEP encryption, set by ASCII and Hexadecimal mode
- ✓ Smart selection function
- ✓ Mini PCI type IIIB form factor
- ✓ Site survey function.
- ✓ Hardware Radio on/off function
- ✓ Support MicroSoft Windows XP, 2000, ME, and 98SE
- ✓ Interoperability – Complying with WiFi



- ✓ WPA, WPA-PSK
- ✓ Super A/G.

## 2. Hardware Architecture

### 2.1 Hardware Block Diagram

The major internal components and external interfaces of the CM9-GP (RoHS) are illustrated in Figure 1-1.

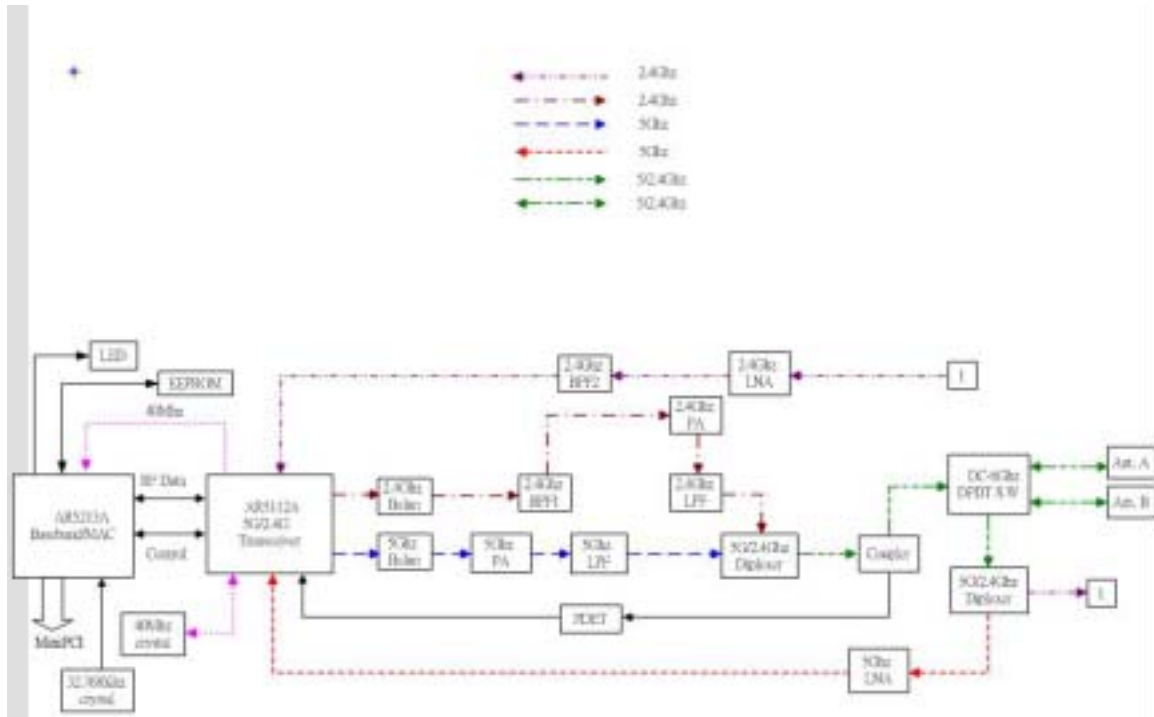

Figure 1-1 CM9-GP (RoHS) Major Component and System Interface

### 2.2 Main Chipset Information

Item	Vender	Model #
MAC/BBP	Atheros	AR5213A
Dual Band/Multi Mode Radio Transceiver	Atheros	AR5112A

#### 2.2.1 MAC/Baseband Processor

The Atheros AR5213A is part of the AR5004 solutions for 5GHz and 2.4GHz wireless local area networks. The AR5213A integrates multi-protocol media access control, a baseband processor, a PCI/Cardbus host interface, analog-to-digital, and digital-to-analog converters.

#### 2.2.2 5GHz Radio Transceiver

The AR5112A chip is an integrated CMOS radio transceiver that supports the IEEE 802.11a, 802.11b, and 802.11g standard. The chip supports connection to an external output booster for higher performance.



### 2.3 Antenna Connector

Two antenna connectors (HRS U.FL-R-SMT) are provided to support antenna diversity.

### 2.4 LED Function

State	LED_0	LED_1
Power save mode	Slow-rate blink	OFF
Awake from power save mode, can be used to indicate power is applied.	ON	OFF
Looking for network association	Alternate blink between LED_0 and LED_1	Alternate blink between LED_0 and LED_1
Associated or joined with network; no activity	Slow-rate blink	Slow-rate blink
Associated or joined with network; blink rate increases with activity	Blink	Blink
Power off	OFF	OFF

### 2.5 Pin Definition

Pin Number	Pin Name	Pin I/O Type	Description
1	TIP	NC	No use
2	RING	NC	No use
3	8PMJ-3	NC	No use
4	8PMJ-1	NC	No use
5	8PMJ-6	NC	No use
6	8PMJ-2	NC	No use
7	8PMJ-7	NC	No use
8	8PMJ-4	NC	No use
9	8PMJ-8	NC	No use
10	8PMJ-5	NC	No use
11	LED1_GRNP	Output, 12mA	LED1 anode
12	LED2_YELP	Output, 12mA	LED2 anode
13	RF_Disable	Input,	Connect to GND (drive low) to disable



			RF, open (drive high) to enable RF.
14	LED2_YELN	Input,	Direct connect to GND
15	CHSGND	Ground	Digital Ground
16	RESERVED	NC	Reserved
17	INTB#	NC	No use
18	5V	NC	5V, no use
19	3.3V	Power	3.3V+/-5%
20	INTA#	CMOS, Output	PCI bus Interrupt A
21	RESERVED	NC	Reserved
22	RESERVED	NC	Reserved
23	GROUND	Ground	Digital ground
24	3.3VAUX	Power	3.3V+/-5%
25	CLK	Input, Weak pull down	Providing timing for all transactions on the PCI bus
26	RST#	Input, Weak pull up	PCI reset
27	GROUND	Ground	Digital ground
28	3.3V	Power	3.3V+/-5%
29	REQ#	Output	PCI bus request
30	GNT#	Input, Weak pull high	PCI bus grant
31	3.3V	Power	3.3V+/-5%
32	GROUND	Ground	Digital ground
33	AD[31]	BiDir., Weak pull down	PCI address/data bus bit 31
34	PME#	Output	Power Management Event Output
35	AD[29]	BiDir., Weak pull down	PCI address/data bus bit 29
36	RESERVED	NC	Reserved
37	GROUND	Ground	Digital ground
38	AD[30]	BiDir., Weak pull down	PCI address/data bus bit 30



39	AD[27]	BiDir., Weak pull down	PCI address/data bus bit 27
40	3.3V	Power	3.3V+/-5%
41	AD[25]	BiDir., Weak pull down	PCI address/data bus bit 25
42	AD[28]	BiDir., Weak pull down	PCI address/data bus bit 28
43	RESERVED	NC	Reserved
44	AD[26]	BiDir., Weak pull down	PCI address/data bus bit 26
45	C/BE[3]#	BiDir., Weak pull up	PCI bus commands and byte 3 enables
46	AD[24]	BiDir., Weak pull down	PCI address/data bus bit 24
47	AD[23]	BiDir., Weak pull down	PCI address/data bus bit 23
48	IDSEL	Input, Weak pull down	Initialization device select
49	GROUND	Ground	Digital ground
50	GROUND	Ground	Digital ground
51	AD[21]	BiDir., Weak pull down	PCI address/data bus bit 21
52	AD[22]	BiDir., Weak pull down	PCI address/data bus bit 22
53	AD[19]	BiDir., Weak pull down	PCI address/data bus bit 19
54	AD[20]	BiDir., Weak pull down	PCI address/data bus bit 20
55	GROUND	Ground	Digital ground
56	PAR	BiDir, Weak pull up	PCI bus parity
57	AD[17]	BiDir., Weak pull down	PCI address/data bus bit 17
58	AD[18]	BiDir., Weak pull down	PCI address/data bus bit 18
59	C/BE[2]#	BiDir., Weak pull up	PCI bus commands and byte 2 enables
60	AD[16]	BiDir., Weak pull down	PCI address/data bus bit 16
61	IRDY#	BiDir., Weak pull up	PCI initiator ready
62	GROUND	Ground	Digital ground
63	3.3V	Power	3.3V+/-5%
64	FRAME#	BiDir., Weak pull down	PCI frame.





65	CLKRUN#	Input, Weak pull up	Control signal for PCI clock
66	TRDY#	BiDir,, Weak pull up	PCI target ready
67	SERR#	BiDir, Weak pull up	PCI system error
68	STOP#	BiDir, Weak pull up	PCI cycle stop signal
69	GROUND	Ground	Digital ground
70	3.3V	Power	3.3V+/-5%
71	PERR#	BiDir, Weak pull up	PCI bus parity
72	DEVSEL#	BiDir, Weak pull up	PCI device select
73	C/BE[1]#	BiDir, Weak pull down	PCI bus commands and byte 1 enables
74	GROUND	Ground	Digital ground
75	AD[14]	BiDir, Weak pull down	PCI address/data bus bit 14
76	AD[15]	BiDir, Weak pull down	PCI address/data bus bit 15
77	GROUND	Ground	Digital ground
78	AD[13]	BiDir, Weak pull down	PCI address/data bus bit 13
79	AD[12]	BiDir, Weak pull down	PCI address/data bus bit 12
80	AD[11]	BiDir, Weak pull down	PCI address/data bus bit 11
81	AD[10]	BiDir, Weak pull down	PCI address/data bus bit 10
82	GROUND	Ground	Digital ground
83	GROUND	Ground	Digital ground
84	AD[09]	BiDir, Weak pull down	PCI address/data bus bit 9
85	AD[08]	BiDir, Weak pull down	PCI address/data bus bit 8
86	C/BE[0]#	BiDir, Weak pull up	PCI bus commands and byte 0 enables
87	AD[07]	BiDir, Weak pull down	PCI address/data bus bit 7
88	3.3V	Power	3.3V+/-5%
89	3.3V	Power	3.3V+/-5%
90	AD[06]	BiDir, Weak pull down	PCI address/data bus bit 6



91	AD[05]	BiDir, Weak pull down	PCI address/data bus bit 5
92	AD[04]	BiDir, Weak pull down	PCI address/data bus bit 4
93	RESERVED	NC	Reserved
94	AD[02]	BiDir, Weak pull down	PCI address/data bus bit 2
95	AD[03]	BiDir, Weak pull down	PCI address/data bus bit 3
96	AD[00]	BiDir, Weak pull down	PCI address/data bus bit 0
97	5V	NC	No use
98	RESERVED_WIP4	NC	Reserved
99	AD[01]	BiDir, Weak pull down	PCI address/data bus bit
100	RESERVED_WIP4	NC	Reserved
101	GROUND	Ground	Digital ground
102	GROUND	Ground	Digital ground
103	AC_SYNC	NC	No use
104	M66EN	NC	PCI 66MHz Enable, no use
105	AC_SDATA_IN	NC	No use
106	AC_SDATA_OUT	NC	No use
107	AC_BIT_CLK	NC	No use
108	AC_CODEC_ID0#	NC	No use
109	AC_CODEC_ID1#	NC	No use
110	AC_RESET#	NC	No use
111	MOD_AUDIO_MON	NC	No use
112	RESERVED	NC	Reserved
113	AUDIO_GND	Ground	Analog ground
114	GROUND	Ground	Digital ground
115	SYS_AUDIO_OUT	NC	No use
116	SYS_AUDIO_IN	NC	No use

117	SYS_AUDIO_OUT GND	NC	No use
118	SYS_AUDIO_IN GND	NC	No use
119	AUDIO_GND	NC	No use
120	AUDIO_GND	Ground	Analog ground
121	RESERVED	NC	Reserved
122	MPCIACT#	NC	Mini PCI function active, no support
123	VCC5VA	NC	No use
124	3.3VAUX	Power	3.3V+/-5%

## 2.6 Radio On/Off Mechanism Suggestion:

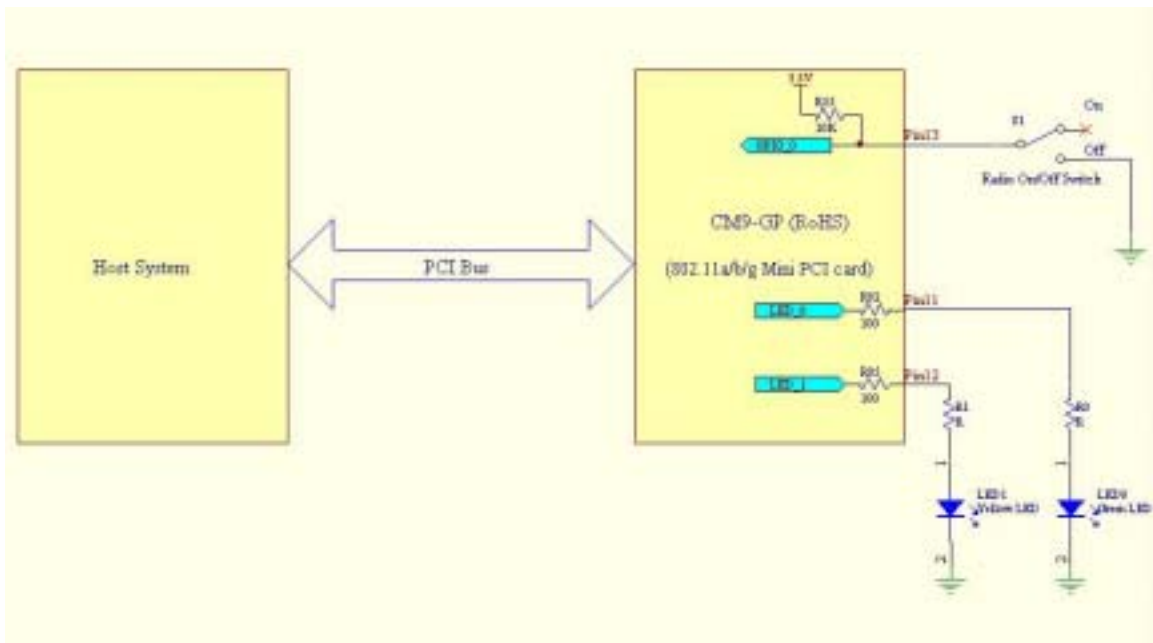

Note:

The value of R82 and R85 is 187 ohm. The value of R0 and R1 is user defined for LED current limitation.



### 3. Software Specification

General Function	
Operation System Support	Windows® 98SE, Me, 2000, XP, and NT4.0SP6
Network Access Mode	IEEE 802.11a Infrastructure / Ad-Hoc Mode, IEEE 802.11b Infrastructure / Ad-Hoc Mode , and IEEE 802.11g Infrastructure / Ad-Hoc Mode
Site Survey	Support Access Points and IEEE 802.11a/b/g Ad-Hoc Networks Scanning Capability
Information List	Selected Profile Information, Link Information, and TCP/IP Information
Profile	Configuration Name
Network Name (SSID)	This is the name of the IEEE 802.11a/b/g wireless network
Network Connection	Define whether the STA is configured for an ad-hoc or infrastructure network
Power Saving	Allow the power management options: Off, Normal, and Maximum
Wireless Mode	Specify 802.11a mode, 802.11b mode, 802.11g mode, or Auto-Select operation
Start Ad-Hoc Network	Specify a band to establish an Ad-Hoc network
Turbo Mode	For 802.11a radio space (5GHz, 108Mbps)
802.11g Support	For 54Mbps mode at 2.4 GHz
QoS	Cooperate in a network using Quality of Service

Security Setting	
Encryption Type	WEP, AES, and Auto
Authentication	802.1x, WPA, WPA-PSK, WPA2, CCX
Shared Keys	Define a set of shared encryption keys
Key Length	64 bits (HEX / ASCII), 128 bits (HEX / ASCII), and 152 bits (HEX / ASCII) Encryption

Feature	
Smart Select --- Automatically scanning available either 802.11a ,802.11b, or 802.11g Access Point and switching connection by desire	
Automatically fall back data rate if signal strength become weakness	
Seamless roaming cross 802.11a, 802.11b, and 802.11g Access Point covered distance	
Future support 802.11d(Regulatory Domain), 802.11e(Quality of Service), and 802.11h(TPC/DFS)	
Automatic data rate and channel selection	
Vivid and user-friendly configuration tool	
WECA Wi-Fi / Wi-Fi5 compliant	
Support 802.1x, WPA, WPA-PSK, WPA2 authentication	
Support WEP-64, WEP-128, WEP-152 and AES encryption	
Cisco CCX support	
Support for SuperA/G	

**4. Appearance**

**4.1.1 3D View**

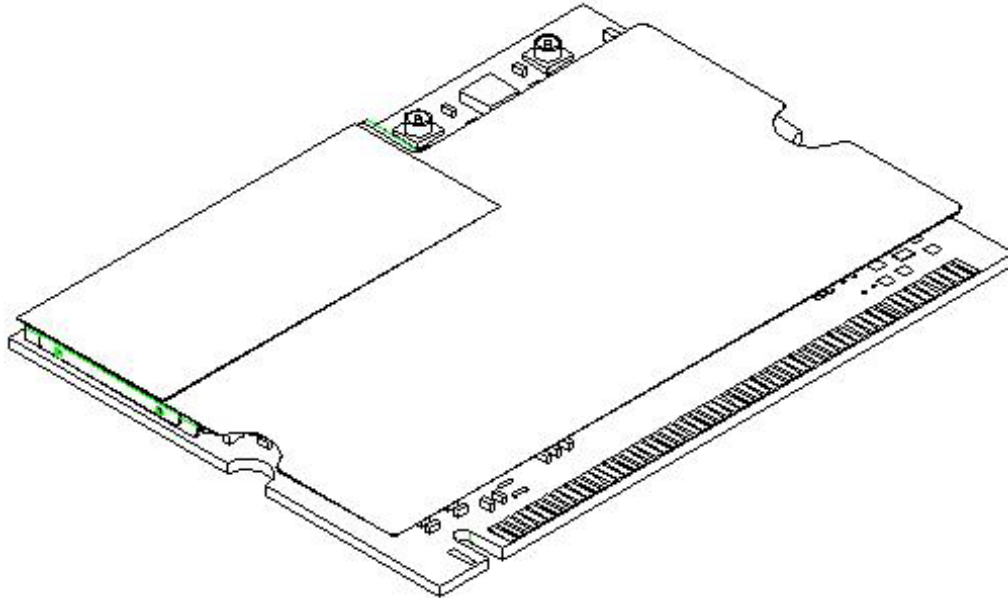

**4.1.2 Top View**

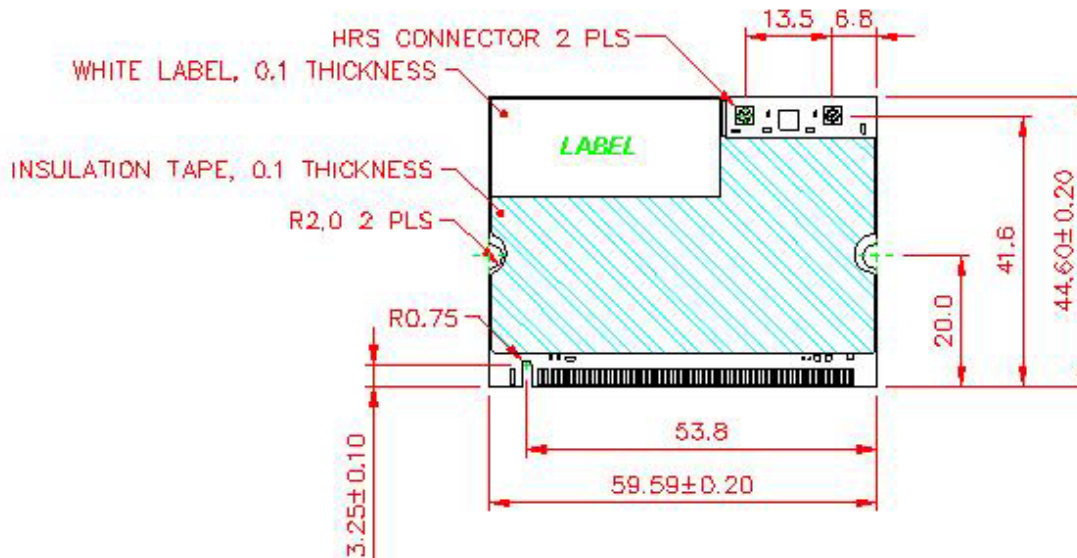

**4.1.3 Side View**

# wistron

## Wistron NeWeb

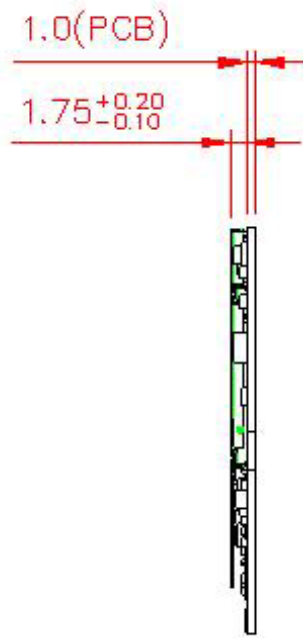

### 5. Packing Standard

#### 5.1 Packing Box

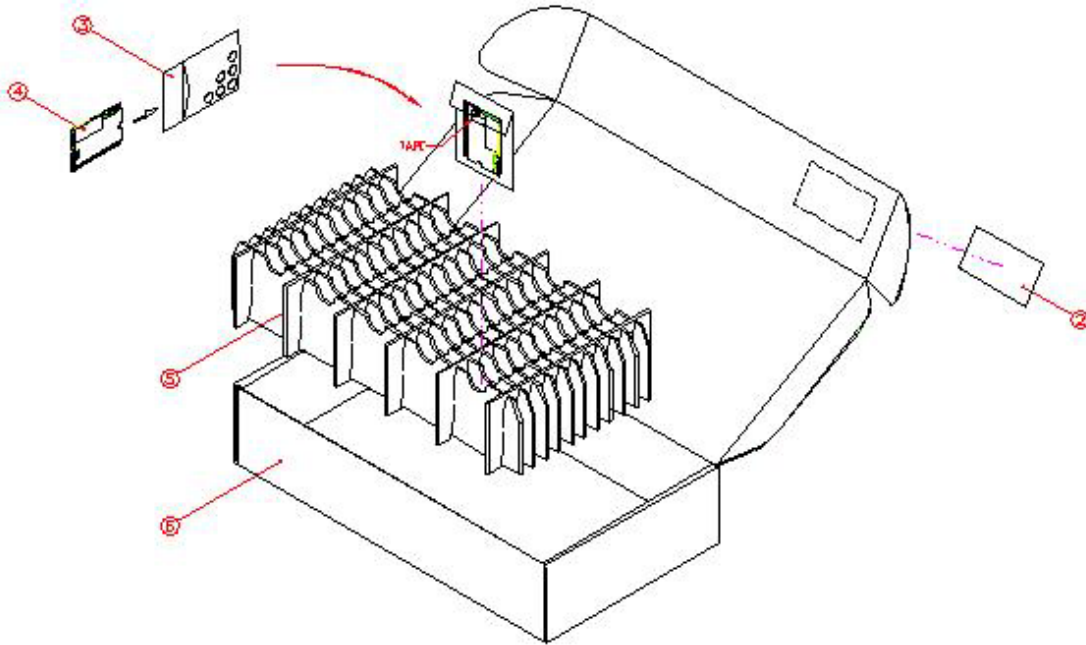

#### 5.2 Carton

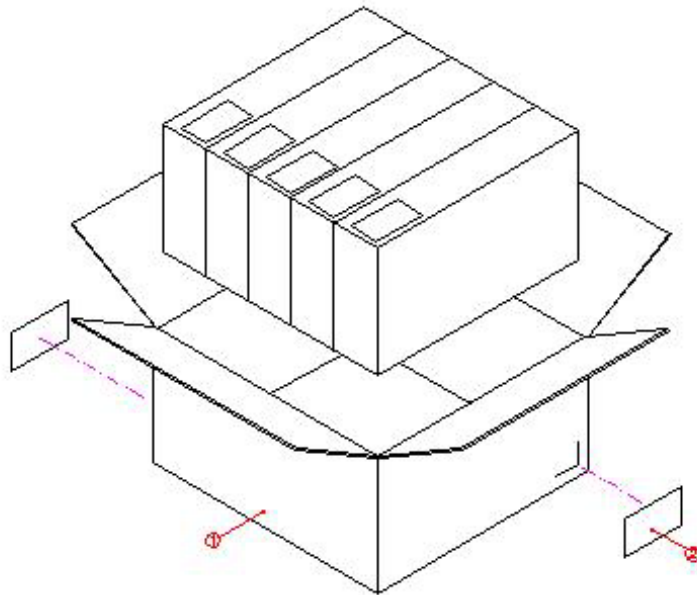

## 6. Specifications

### 6.1 Wireless LAN

- Form Factor: Mini PCI Type 3B
- Frequency band:
  - A Mode: 5.15~5.35 & 5.725~ 5.825 GHz for US  
4.9~5.25 GHz for Japan (Subject to change)  
5.15~5.35 & 5.47~5.725 GHz for ETSI
  - B/G Mode: 2400~2483.5 MHz (for US, Canada, ETSI, and Japan)  
2471~2497 MHz (for Japan)
- Channel Spacing:
  - A Mode: 20MHz
  - B/G Mode: 5MHz
- Modulation:
  - A Mode: OFDM with BPSK, QPSK, QAM, and 64QAM
  - B Mode: DSSS with DBPSK, DQPSK, and CCK
  - G Mode: OFDM with BPSK, QPSK, QAM, and 64QAM  
DSSS with DBPSK, DQPSK, and CCK
- Host interface: Mini PCI V1.0
- Channels Support:
  - A Mode: US: 12 (Ch:36,40,44,48,52,56,60,64,149,153,157, 161)  
Japan: 4 (Ch:34,38,42,46)and 7( 4.92, 4.94, 4.96, 4.98, 5.04, 5.06, 5.08GHz) (Subject to change)  
ETSI:19(Ch:36,40,44,48,52,56,60,64,100,104,108, 112,116,120,124,128,132,136,140)
  - B/G Mode: US/Canada: 11 (1~11)  
ETSI: 13 (1~13)  
France: 4 (10~13)  
Japan: 14 (1~14) for 11b mode  
Japan: 13(1~13) for 11g mode
- Supply Voltage: 3.3V±5% DC



- Current Consumption:
  - A Mode:
    - FTP Tx: 360mA (typical)~410mA (max)
    - FTP Rx: 310mA (typical)~350mA (max)
    - Stand by: 270mA (typical)~310mA (max)
    - Cont. Tx: 510mA(typ.)~ 595mA(max) <19dBm output>
    - Cont. Rx: 260mA(typ.)~ 300mA(max)
  - B Mode:
    - FTP Tx: 430mA (typical)~470mA (max)
    - FTP Rx: 310mA (typical)~350mA (max)
    - Stand by: 250mA (typical)~290mA (max)
    - Cont. Tx: 500mA(typ.)~ 570mA(max) <19.5dBm output>
    - Cont. Rx: 240mA(typ.)~ 280mA(max)
  - G Mode:
    - FTP Tx: 350mA (typical)~400mA (max)
    - FTP Rx: 310mA (typical)~350mA (max)
    - Stand by: 280mA (typical)~320mA (max)
    - Cont. Tx: 500mA(typ.)~ 580mA(max) <19.5dBm output>
    - Cont. Rx: 275mA(typ.)~ 315mA(max)
  - Power saving: 20mA (typical)~40mA (max)
  - Radio off: 20mA (typical)~40mA (max)
- Radio Power:
  - A Mode:
    - +18dBm @ 6Mbps
    - +12dBm @ 54Mbps
  - B Mode:
    - +19dBm @ 1&2Mbps
    - +19dBm @ 5.5&11Mbps
  - G Mode:
    - +19dBm @ 6Mbps
    - +14dBm @ 54Mbps
- Sensitivity:
  - A Mode:
    - 87dBm @ 6Mbps
    - 67dBm @ 54Mbps
  - B Mode:
    - 87dBm @ 11Mbps
    - 94dBm @ 1Mbps
  - G Mode:
    - 87dBm @ 6Mbps
    - 70dBm @ 54Mbps



- Operating Range:
  - A Mode: Indoor: 35~100 meter @ 6Mbps  
Outdoor: over 350 meter @ 6Mbps
  - B Mode: Indoor: 35~100 meter @ 11Mbps  
Outdoor: over 350 meter @ 11Mbps
  - G Mode: Indoor: 35~100 meter @ 6Mbps  
Outdoor: over 350 meter @ 6Mbps
- Media Access Protocol: CSMA/CA with ACK

### **5.2 Environmental Spec.**

- Operating Temperature Range: 0degree C~70degree C
- Storage Temperature Range: -20degree C~80degree C
- Operating Humidity Range: 5%~90%

## 7. EQT Test Items and Result

Throughput Value before testing: A

Throughput Value after testing: B

$$(B-A/A) * 100\% = C$$

The value range of C must be within -10%.

### EQT Test Items:

No.	Test Items	DUT Status	Testing Condition	Test Result
1	Storage test / High Temp	Non-operation	Temperature: 80 , R.H.: 90% Duration: 72 hours	PASS
2	Storage test / Low Temp.	Non-operation	Temperature: -20 , Duration: 72 hours	PASS
3	Operation test / High Temp	Non-operation	Temperature:70 , R.H.: 90% Duration: 24 hours	PASS
4	Operation test / Low Temp.	Non-operation	Temperature: -10 , Duration: 24hours	PASS
5	Thermal Shock	Non-Operation	Temperature: -20 ~ +80 , Hold Time: 30 mins Total Cycle: 20 times	PASS
6	Drop Test	Non-Operation	Height : 30cm 6 faces, 3drops/face onto plastic-tile	PASS
7	Single vibration	Operation	Frequency Range: 5~2000 HZ Total Gram: 1 Grms Axis of vibration: X,Y,Z axes Test Duration: 1 hours/axis	PASS

## EQT Test Result:

No	Test Item	Sample Q'ty	Test Duration	Sample ID	Before(g)		End(g)		Deviation		Check
					Tx	Rx	Tx	Rx	(E-B/B)*100%		
1	Storage / High 80 ,90%H	4	2/15~18	3	22.67	22.32	22.73	22.52	0.3%	0.9%	PASS
				4	22.58	22.47	22.6	22.33	0.1%	-0.6%	PASS
				8	21.78	22.62	22.3	22.08	2.4%	-2.4%	PASS
				11	21.96	22.4	21.35	23.09	-2.8%	3.1%	PASS
2	Storage / Low -20	4	2/15~18	1	22.16	22.66	22.66	23.22	2.3%	2.5%	PASS
				2	22.51	22.29	22.43	22.12	-0.4%	-0.8%	PASS
				9	22.14	22.32	22.14	22.67	0.0%	1.6%	PASS
				10	22.22	22.36	22.62	22.00	1.8%	-1.6%	PASS
3	Operation / High 70 ,90%H	4	2/13~14	1	22.16	22.66	22.18	22.61	0.1%	-0.2%	PASS
				2	22.51	22.29	22.26	22.15	-1.1%	-0.6%	PASS
				3	22.67	22.32	22.96	22.85	1.3%	2.4%	PASS
				4	22.58	22.47	22.07	23.06	-2.3%	2.6%	PASS
4	Operation / Low -10	4	2/14~15	3	22.67	22.32	23.02	22.59	1.5%	1.2%	PASS
				4	22.58	22.47	23.16	22.27	2.6%	-0.9%	PASS
				5	22.19	22.61	23.18	22.37	4.5%	-1.1%	PASS
				6	22.29	22.1	23.24	22.88	4.3%	3.5%	PASS
5	Thermal Shock -20~80	4	2/13~14	5	22.19	22.61	23.31	23.29	5.0%	3.0%	PASS
				6	22.29	22.1	22.96	22.31	3.0%	1.0%	PASS
				7	22.09	22.49	21.25	22.57	-3.8%	0.4%	PASS

				8	21.78	22.62	21.31	22.59	-2.2%	-0.1%	PASS
6	Drop Test 30cm	2	2/13	9	22.14	22.32	23.12	23.07	4.4%	3.4%	PASS
				10	22.22	22.36	23.32	22.94	5.0%	2.6%	PASS
7	Single Vibration 1G	2	2/17	5	22.19	22.61	22.87	22.43	3.1%	-0.8%	PASS
				6	22.29	22.1	22.56	22.76	1.2%	3.0%	PASS

## MTBF Test:

### Preparation of experiment

- Sample size: 10 pcs
- Supply Voltage: +3.3V
- Output Load: Power-On
- Stress Temperature: 60
- Confidence Level: 90%
- Demonstrate MTBF: 3 years

### Calculation

$$AF \text{ (Acceleration Factor)} = \exp \left[ \frac{E_a}{B} \left( \frac{1}{T_u} - \frac{1}{T_a} \right) \right] = 31.44$$

Where  $E_a$ : Activation Energy (1.0eV)

$T_u$ : Normal Operation Temperature, 30 (303°K)

$T_a$ : Accelerating Temperature, 60 (333°K)

B: Boltzmanns Constant,  $8.623 \times 10^{-5} \text{ eV/}^\circ\text{K}$

gth non-replacement test plan

Where T: the total accumulated test time



C: the confidence level

R: number of failure

**Expected Test Length:**

Failure Number (When)	Test Duration -Hours ( > X )	Expected MTBF- Year ( > Y )
0	2160 hours ( 10 pcs , 9 days )	> 3
1	3360 hours ( 10 pcs , 14 days )	> 3
2	4560 hours ( 10pcs , 19 days )	> 3



**RESULT**

2006/2/22		2006/2/24		2006/2/26		2006/2/28		2006/3/2		2006/3/4		Check
Original		A2		A4		A6		A8		A10		
Tx	Rx	Tx	Rx	Tx	Rx	Tx	Rx	Tx	Rx	Tx	Rx	
22.16	22.66	21.46	21.95	21.37	22.03	21.47	21.89	21.08	21.31	21.16	21.82	PASS
22.51	22.29	21.78	21.72	21.63	21.75	21.78	21.67	21.87	21.84	21.72	21.53	PASS
22.67	22.32	21.87	21.52	21.95	21.56	21.83	21.35	21.89	21.27	21.8	21.68	PASS
22.58	22.47	21.22	22.02	21.38	22.07	20.97	22.18	21.17	21.97	21.21	21.99	PASS
22.19	22.61	21.39	22.14	21.26	21.43	21.42	21.78	21.31	21.34	21.39	21.93	PASS
22.29	22.1	21.08	21.39	21.32	21.12	21.24	21.03	21.24	21.59	21.04	21.72	PASS
22.09	22.49	21.85	22.03	21.85	21.43	21.99	21.89	21.79	21.36	21.85	21.72	PASS
21.78	22.62	21.49	22.11	21.54	22.04	21.72	22.16	21.71	21.88	21.62	21.91	PASS
22.14	22.32	21.8	22.17	21.86	22.04	21.71	22.1	21.67	22.33	21.72	22.16	PASS
22.22	22.36	21.56	21.58	21.61	22.01	21.94	21.69	21.92	22.43	21.69	21.99	PASS

**COPYRIGHT DECLARATION**

**Copyright (c) 2002 by Wistron Neweb Corporation. All rights reserved.**

*The drawings, specifications and the data contain herein are the exclusive property of Wistron Neweb Corp. issued in strict confidence and shall not, without the prior written permission of Wistron Neweb Corp., be reproduced, copied or used, in parts or as a whole, for any purpose whatsoever, except the manufacture of articles for Wistron Neweb Corp.*

*WNC makes no warranties with respect to the correctness, accuracy or wholeness of this specification. The information in this document is subject to change without notice. WNC reserves the right to make revisions to this document and the product described herein without obligation to notify any person or entity of any such changes.*



**WARNING**

*This document is intended for **internal** use only. A Non-Disclosure Agreement (**NDA**) is required to release this document under any circumstances.*